SELECTRONIX, INC.
WOODINVILLE, WA

SUPERSTEP 2100 SERIES
SEQUENCING PROPORTIONAL
LOAD CONTROLLERS

INSTALLATION & OPERATING
MANUAL

- **Models:** SLC2102-SLC2112
SLC2102X-SLC2112X
SLC2152-SLC2162
SLC2170-xx
- **Relay Output**
- **UL Recognized for U.S. and Canada File E124742**

TABLE OF CONTENTS

SECTION	SUBJECT	PAGE
1.	GENERAL INFORMATION	4
1.1	INTRODUCTION.....	4
1.2	BASIC CONTROL UNITS	4
1.3	EXPANDABLE CONTROL UNITS	5
1.4	EXPANSION UNITS.....	5
1.5	REMOTE INDICATOR PANEL	5
1.6	CABLES.....	6
2.	INSTALLATION.....	6
2.1	INPUT JUMPERS	7
2.1.1	<i>Jumper Combinations for Various Input Types</i>	7
2.1.2	<i>Description of Jumper Function</i>	7
2.2	OUTPUT JUMPERS.....	8
2.2.1	<i>Expandable Control Unit</i>	8
2.2.2	<i>Expansion Units</i>	8
2.3	FIELD WIRING - SHIELDING AND GROUNDING	12
2.3.1	<i>Shielding</i>	12
2.3.2	<i>Grounding</i>	12
2.3.3	<i>Honeywell-Selectronix Terminal Designation Cross-Reference</i>	12
2.4	PHYSICAL AND ELECTRICAL INSTALLATION.....	13
3.	SENSORS / INTERFACE SIGNALS	14
3.1	STANDARD VOLTAGE INPUTS.....	14
3.2	STANDARD CURRENT INPUT.....	14
3.3	OHMIC (SLIDEWIRE).....	14
3.4	CONTACT CLOSURE	14
3.5	EXAMPLES OF COMPATIBLE CONTROLLERS AND SENSORS.....	14
3.6	CONTROLLERS NOT RECOMMENDED	14
4.	OPERATING INSTRUCTIONS.....	16
4.1	STARTUP AND ADJUSTMENTS.....	16
5.	TROUBLESHOOTING	17
5.1	TROUBLESHOOTING TIPS.....	18
6.	SPECIFICATIONS.....	19

LIST OF FIGURES

FIGURE 1	CONTROL OR EXPANSION UNIT - SMALL CHASSIS.....	9
FIGURE 2	CONTROL OR EXPANSION UNIT - LARGE CHASSIS.....	10
FIGURE 3	REMOTE INDICATOR PANEL BOARD LAYOUT.....	11
FIGURE 4	REMOTE INDICATOR PANEL MOUNTING HOLES.....	11
FIGURE 5	FIELD WIRING DIAGRAM.....	15

1. GENERAL INFORMATION

1.1 Introduction

The **SELECTRONIX, INC. SUPERSTEP 2100 SERIES** controllers are all solid-state, fully sequencing proportional load controllers for use in staged electric heating systems. It provides multi-stage relay contact closures in proportional response to a slidewire sensor, potentiometer, voltage, or current inputs.

An Expandable Control Unit can be combined with Expansion Units to provide a maximum of 36 stages.

- Two different chassis sizes are available. The small chassis handles up to 6 output stages. The larger chassis handles up to 12 output stages.
- The Control Unit is compatible with a number of different input signal types, including, 0-1VDC, 2-10VDC, 4-20 maDC, and ohmic slidewire. The input signal type is selected with on-board jumpers.
- All outputs are relay contacts, which are intended to be used in pilot operation of relays or contactors of less than 125 VA burden.

The relays are conservatively rated for this application. (They carry a UL rating of 8A resistive @ 125/250 VAC). Each relay contact set has a varistor wired in parallel to suppress contact arcing due to inductive kickback from contactor coils or other inductive loads, thus extending the life of the pilot relays.

- Each output stage also has an LED indicator to show output operation.
- Step timing is adjusted by a potentiometer located on the on the Control Unit.
- All Control and Expansion Units are provided with standoffs suitable for mounting to chassis panels using #6 machine screws.
- The Superstep Series controllers are Recognized under the UL Component's Program and are intended for use by Original Equipment Manufacturers (OEM) who will seek overall UL approval for the end-item system. UL File E124742 in accordance with XAPX2 classification.

1.2 Basic Control Units

Basic Control Units are intended for those users who have no need for expansion capability or remote indicator panels.

Standard configurations are 4, 6, 8, 10, or 12 stages, however any amount of output stages between 2 and 12 can be special-ordered.

Ordering Information: SLC21nn

where nn is the quantity of stages from 02 through 12. Example: SLC2106 is for a 6 step board. Even number of stages are standard stock items, but odd number of stages may be special ordered.

1.3 Expandable Control Units

Expandable Control Units are intended for those users who want the capability to increase the number of output stages or who want to use the Remote Indicator Panel. The Expandable Control Unit can be used in stand-alone operation or in combination with 1 or 2 Expansion Units. This provides the OEM with the flexibility of purchasing a single unit which can later be used in different applications, thus reducing inventory requirements.

Sequencing and output proportionality of the added stages are maintained without any additional adjustments or calibration.

These units include the connector to attach the optional Remote Indicator Panel.

Ordering Information: SLC21nnX

where nn is the quantity of stages from 02 through 12. Example: SLC2108X is for an 8 step board.
Even number of stages are standard stock items, but odd number of stages may be special ordered.

1.4 Expansion Units

Expansion units are used in combination with an Expandable Control Unit. Up to 2 Expansion Units can be connected to the Expandable Control Unit to provide up to 36 output stages. Sequencing and output proportionality of all stages is maintained.

They are available in two chassis sizes which can add between 2 and 12 stages per unit. The small chassis accommodates the 2, 4, or 6 stage configuration, while the large chassis accommodates the 8, 10, or 12 stage configuration.

A 2-unit Cascading Cable is included with the Expansion Unit.

A 3-unit Cascading Cable is available as an option.

These units include the connector to attach the optional Remote Indicator Panel.

Ordering Information: SLC21nn

where nn is the quantity of stages from 02 through 12 + 50. Example: SLC2158 is for an 8 step expansion board.

Even number of stages are standard stock items, but odd number of stages may be special ordered.

1.5 Remote Indicator Panel

A Remote Indicator Panel provides LED indications of output stage status at a remote location.

The Panel consists of a printed wiring board and an acrylic plastic cover suitable for mounting behind a cutout on the control cabinet. The Panel is available with up to 12 LED's to match the quantity of stages located on the attached Control or Expansion Unit.

The ordering part number is SLC2170-xx, where xx is the number of installed LED's.

To use the Remote Indicator Panel, the Expandable Control Unit must be ordered, as it provides the required J2 connector. The Expansion Units also provides the J2 connector. A 6 foot flat cable is included with the Indicator Panel.

1.6 Cables

- 1.6.1 A Cascading Cable is required to connect an Expandable Control Unit to the Expansion Units. The Cables are 20 conductor flat cables with either 2 or 3 strain-relieved connectors attached at 15" intervals.

An SLC2195 is included with the Expansion Unit. Cascading Cables are available separately with the capacity to connect either 1 or 2 Expansion Units. *An SLC2196 may be used to cascade 2 units together if additional length of up to 30" is needed.*

Ordering Information:

SLC2195 is a 2-Unit Cascading Cable, which connects an Expandable Control Unit to a single Expansion Unit.

SLC2196 is a 3-Unit Cascading Cable, which connects an Expandable Control Unit to two Expansion Units.

- 1.6.2 The Remote Indicator Panel Cable is a 6' 14-conductor flat cable with strain-relieved connectors at each end. It is used to connect the Remote Indicator Panel to an Expandable Control Unit or to an Expansion Unit. A 6' cable is included with the Remote Indicator Panel option.

Ordering Information: SLC2197 Remote Indicator Panel Cable

2. INSTALLATION

!!! WARNING !!!

THIS EQUIPMENT SHOULD BE INSTALLED, ADJUSTED, AND SERVICED BY QUALIFIED ELECTRICAL MAINTENANCE PERSONNEL FAMILIAR WITH THE CONSTRUCTION AND OPERATION OF THE EQUIPMENT AND THE HAZARDS INVOLVED.

FAILURE TO OBSERVE THIS PRECAUTION COULD RESULT IN BODILY INJURY!

THIS CONTROL IS AN OPERATING DEVICE, NOT A LIMITING DEVICE. IT IS THE RESPONSIBILITY OF THE USER TO INSTALL ALL LIMITING AND SAFETY DEVICES TO THE END-ITEM SYSTEM.

!!! WARNING !!!

THIS CIRCUITRY IN THIS EQUIPMENT CONTAINS STATIC SENSITIVE ELECTRONIC COMPONENTS. OBSERVE PROPER HANDLING PRECAUTIONS WHEN HANDLING THE PRINTED WIRING BOARDS. AVOID CONTACTING COMPONENTS WITHOUT FIRST DISCHARGING YOUR BODY TO GROUND. ALWAYS DISCONNECT POWER TO THE BOARDS BEFORE MAKING ELECTRICAL INTERCONNECT OR OUTPUT WIRING.

FAILURE TO OBSERVE THIS PRECAUTION COULD RESULT IN DAMAGE TO THE CIRCUITRY!

2.1 Input Jumpers

2.1.1 Jumper Combinations for Various Input Types

Signal Type	Jumper 1	Jumper 2	Jumper 3	Remarks
2-10 VDC	E30-E31	E33-E34	E36-E37	Factory Default (+) TB1-2 (-) TB1-3
Ohmic (Slidewire)	E30-E31	E34-E35	E37-E38	Range is 100 - 5,000 ohms
0-1 VDC	E30-E31	E34-E35	E37-E38	(+) TB1-2 (-) TB1-3
4-20 ma	E31-E32	E34-E35	E36-E37	Input resistance is 62 ohms (+) TB1-2 (-) TB1-3
0-10VDC, 0-18VDC	E30-E31	E33-E34	E37-E38	0-10VDC and 0-18VDC is a non-standard range which requires a factory SPECIAL order board.

2.1.2 Description of Jumper Function

Jumper	Function Selected	Applicable Configuration
E30-E31	No current loop resistor between TB-2 and TB-3	2-10VDC;0-10VDC*;0-1VDC; Ohmic
E31-E32	61.9 ohm current loop resistor between TB-2 and TB-3	4-20ma
E33-E34	Input gain = 1	2-10VDC, 0-10VDC*, 0-18VDC*
E34-E35	Input gain = 8	Ohmic; 0-1VDC, 4-20ma
E36-E37	20% input offset	2-10VDC; 4-20ma
E37-E38	No input offset	Ohmic, 0-1VDC, 0-10VDC*

* 0-10VDC and 0-18VDC is a non-standard range which requires a factory **SPECIAL** ordered board.

2.2 Output Jumpers

Basic Control units are ready to be installed in the end system without any additional preparation.

Expandable Control Units and Expansion Units must be configured for the intended application by verifying or moving the supplied plug-in jumpers to the appropriate locations.

Jumper connections are used on the Expandable Control Units and on the Expansion Units to configure them for stand-alone or cascaded operation. The configuration jumpers on all units carry the same reference designations.

Refer to either Figure 1 or Figure 2 to locate the E20-E29 jumper pins.

2.2.1 Expandable Control Unit

QTY EXPANSION UNITS CONNECTED	Jumper 4	Jumper 5	Remarks
0	E20-E21	E28-E29	
1	E20-E21	E27-E28	Factory Default
2	E20-E21	E27-E28	

2.2.2 Expansion Units

QTY EXPANSION UNITS IN SYSTEM	1 OF 1	1 OF 2	2 OF 2	Remarks
1	E21-E22 E26-E27			Factory Default
2		E21-E22 E23-E24	E24-E25 E26-E27	

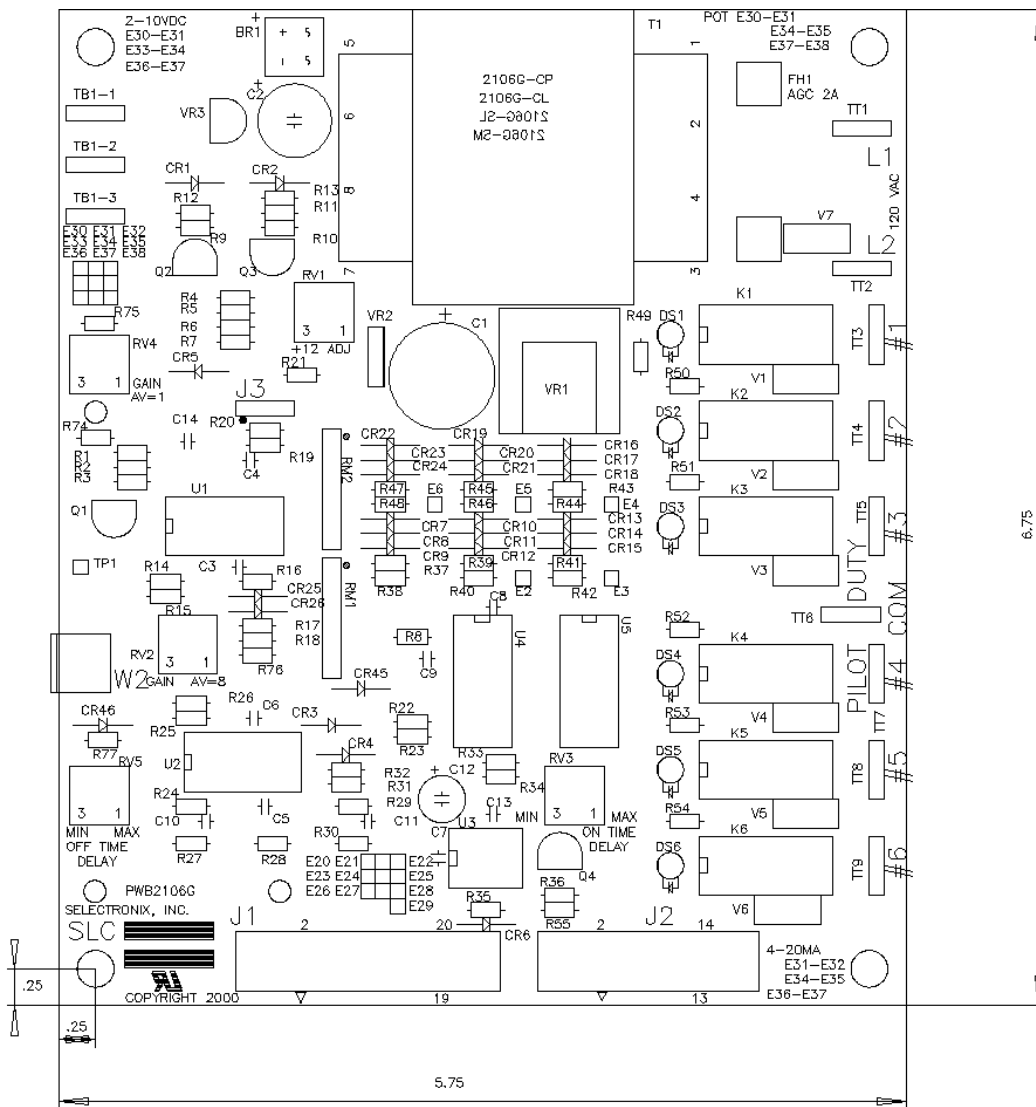

Figure 1 CONTROL OR EXPANSION UNIT - SMALL CHASSIS

APPLICABLE MODEL NUMBERS: SLC2102(X)-SLC2106(X), SLC2152-SLC2156

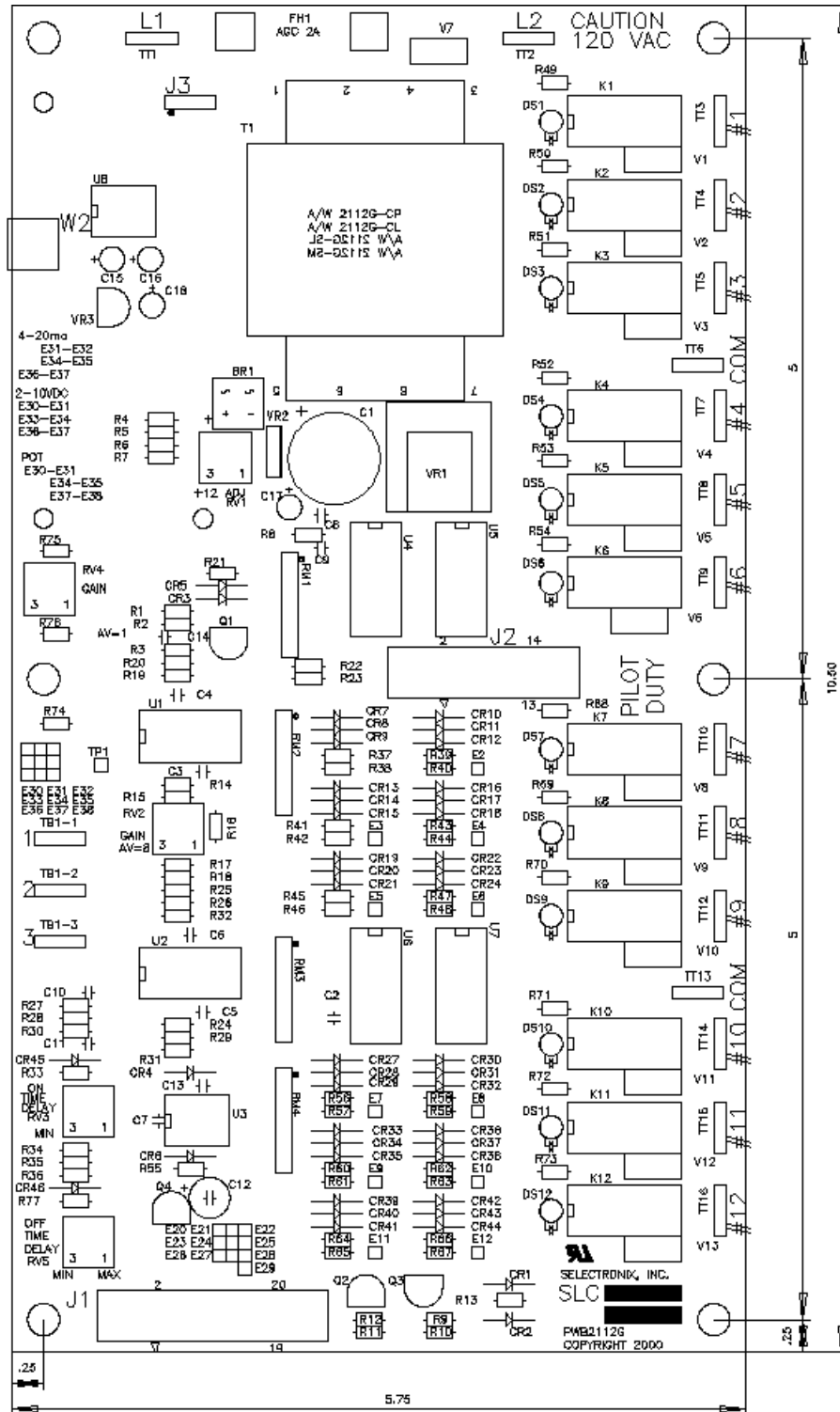

Figure 2 CONTROL OR EXPANSION UNIT - LARGE CHASSIS

APPLICABLE MODEL NUMBERS: SLC2107(X)-SLC2112(X), SLC2157-SLC2162

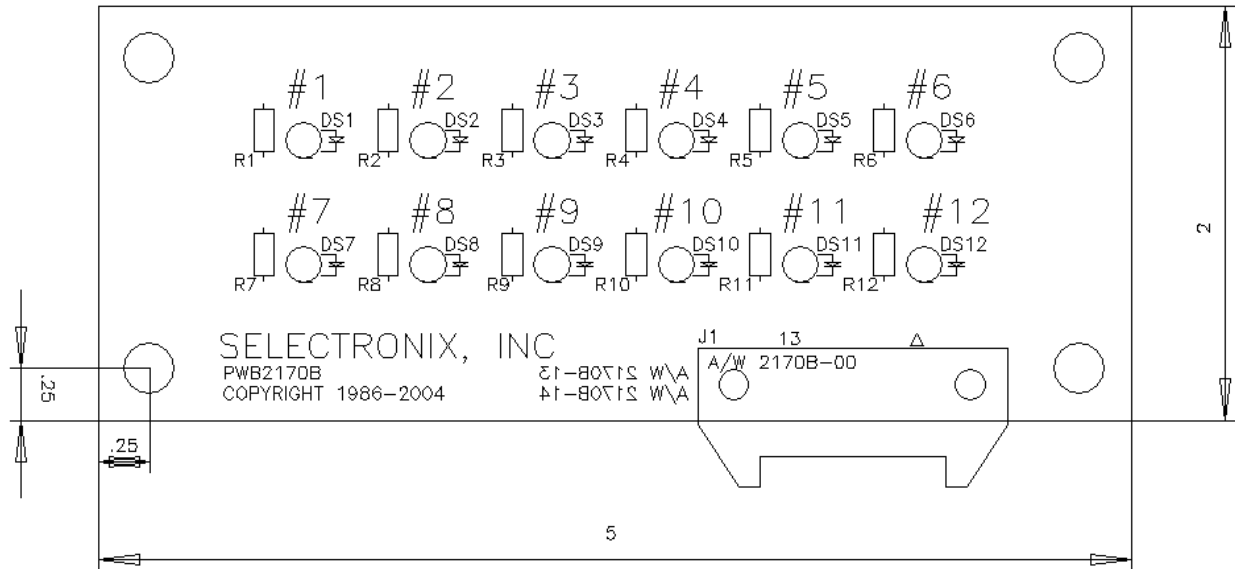

Figure 3 REMOTE INDICATOR PANEL BOARD LAYOUT

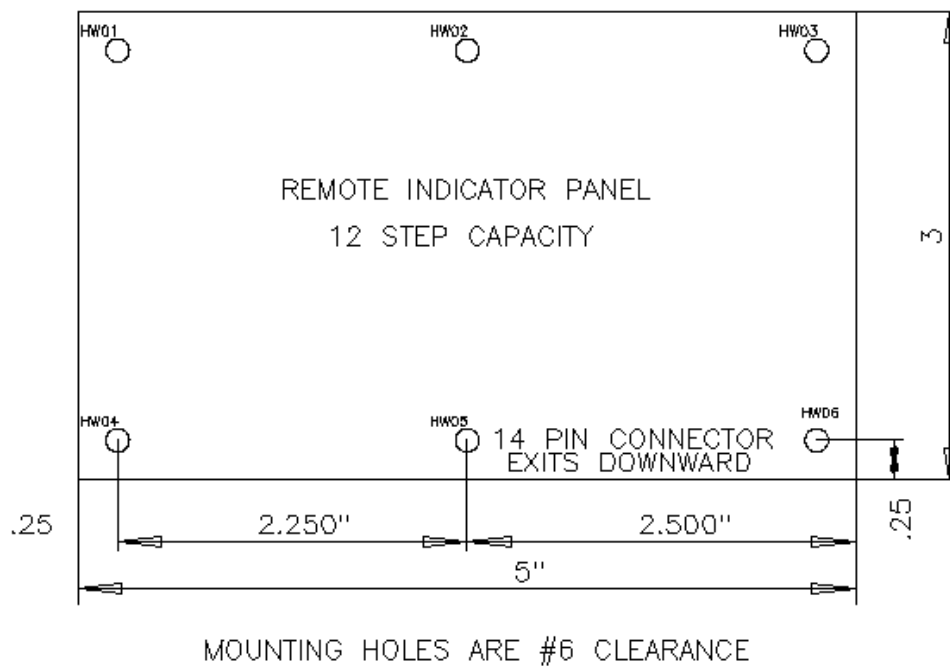

Figure 4 REMOTE INDICATOR PANEL MOUNTING HOLES

2.3 Field Wiring - Shielding and Grounding

2.3.1 Shielding

Shielded twisted pair wire is recommended for suppression of electromagnetic interference (EMI) of the signals that are connected to the command input terminals TB1-TB3, and load limit terminals, TB4-TB6. EMI is transmitted to the signal wires by 3 primary modes:

1. Conductive Noise may be conducted via the power lines from external sources
2. Inductive. EMI may be induced into the signal wires when power wires are in close proximity. Twisted pair wires provide substantial reduction to induced EMI.
3. Capacitive EMI may also be transferred to the signal wires by this mechanism.

As such, route the signal wires with as much separation as is practical from AC power wiring or other sources of EMI. Do not use the same conduit for the signal and AC wiring.

Care must be taken when terminating the shield. The shield should be terminated at only one end, preferably at 1) the signal source's signal common. Optionally 2) the shield may be connected to earth ground, or 3) left totally unterminated.

The best choice is dependent on the characteristics of the individual installation, but it is recommended that the choice start with 1) above, and only change to a different configuration if it does not provide acceptable results.

2.3.2 Grounding

The low voltage circuit common on the Selectronix Superstep controllers is TB1-3. It is an isolated floating common.

The primary concern for proper grounding of the control circuit is to not introduce ground loops on any shielded wiring connected to the controller. This can occur when the shields are terminated at both ends of the wire, and both ends are connected to earth ground.

The floating circuit common accommodates current loop configurations, where the input to the controller is off earth ground.

2.3.3 Honeywell-Selectronix Terminal Designation Cross-Reference

IMPORTANT WIRING CONNECTIONS

Honeywell T775 Electronic/ Selectronix Terminal Designation and Connection

Honeywell Electronic Controllers:

Honeywell P7810

Function	Honeywell Labels		Selectronix Labels	
Command Input (+)	1	W	TB2	R (+)
Command Input (-)	2	R	TB3	W (-)
No Connection	3	B	TB1	

Honeywell Non-Electronic/ Selectronix Terminal Designation and Connection

Slidewire Devices: Honeywell T991A, Honeywell L91A

Function	Honeywell Labels	Selectronix		
Reference Voltage	B	TB1-1 or TB1	B	SLC2100 1.0VDC (+) TB3 (-) SLC4000 1.2VDC (+) TB3 (-)
Wiper Input	R	TB1-2 or TB2	R	
Signal Common	W	TB1-3 or TB3	W	

2.4 Physical and Electrical Installation

- 2.3.1 Review all installation and wiring instructions thoroughly before proceeding.
- 2.3.2 Verify that the operating ambient temperatures will be within 5 to 55 degrees C. (41 to 131 degrees F).
- 2.3.3 Mount the Control Unit and any Expansion Units by using 6-32 machine screws in the standoffs provided.

See Figure 1 (Small chassis) or Figure 2 (Large chassis) for the physical mounting dimensions.

Mount the Remote Indicator Panel behind a 2" x 4" rectangular cutout, using the six #6 holes provided.

Refer to Figure 3 for the physical mounting dimensions.

- 2.3.4 Verify the proper positioning of all jumpers within the controller. See paragraphs 2.1 and 2.2.
- 2.3.5 Connect the Control Unit to the Expansion Unit(s) by the appropriate Cascading Cable.

Verify that both units do not have line power applied, before connecting or disconnecting the Cascading Cables!

Note that the flat cable connectors have a raised rib which fits into a slot in the mating header, preventing incorrect installation.

Verify that the connector ejector levers are properly seated on the connector so as to prevent inadvertent connector release.

- 2.3.6 Verify that all interconnecting wiring is sized and installed in conformance with the National Electrical Code (NEC) and other applicable local codes.
- 2.3.7 Terminate the control wiring by using 1/4" quick-connect female receptacles for all connections.

Control and Expansion Units larger than 6 stages are provided with two "COM" terminals.....terminate both connections for proper capacity.

- 2.3.8 Connect the appropriate sensor or input signal to the Control unit per the wiring diagram shown in Figure 3. See the shielding and grounding considerations in Section 2.3.
- 2.3.9 Connect the cable from any Remote Indicator Panels if used.
- 2.3.10 Verify that the input power to the controller L1 and L2 terminals is 120VAC.
- 2.3.11 Verify that the contactors connected to the pilot relays are for 120VAC.
- 2.3.12 Verify that the L1 (hot) side is connected to the terminal labeled 'COM', and that both terminals are used when more than 6 stages are used per board.

Sensors / Interface Signals

2.5 Standard Voltage Inputs

Standard Voltage Inputs are:

- 2-10 VDC
- 0-1 VDC

2.6 Standard Current Input

- 4-20 ma DC

2.7 Ohmic (Slidewire)

The ohmic input is for variable resistance devices, (including 0-135 ohm slidewire), with the following characteristics:

- Provides 3 wires for connection
- Has a total resistance from end point terminals between 100 and 5000 ohms.
- Has a resistance at the minimum setting that provides the desired output, at that setting.

2.8 Contact Closure

- A contact closure may be used to provide all-on or all-off operation.
- Connect a 10K external resistor between TB2 and TB3 or connect DPST contacts with the NC contact between TB2 and TB3 and the NO contact between TB1 and TB2.

2.9 Examples of Compatible Controllers and Sensors

Suitable sensors are manufactured by Honeywell and other environmental control manufacturers.

- Honeywell Model T775M, T775E, T775F, Electronic Remote Temperature Controller
- Honeywell Model T991A Temperature Sensor (Use Ohmic configuration)
- Honeywell Model L91 Pressure Sensor (Use Ohmic configuration)
- Honeywell Model P7810B, Pressure Controller, 4-20ma output.
- Resistance inputs provided by any potentiometer or slidewire device between 100 ohms and 5K ohms are acceptable.
- Voltage Inputs of 0-1VDC, 2-10VDC (See Section 2.1 for the proper Input Jumper Connections.)
- Current Input of 4-20 ma (See Section 2.1 for the proper Input Jumper Connections.)

2.10 Controllers NOT Recommended

Controllers which provide *simulated* 135 ohm outputs, which are usually used to control valve and damper motors ***are not*** recommended for use as the 135 ohm input to the Superstep 2100 series controllers. Use a device which provides a compatible voltage or current output.

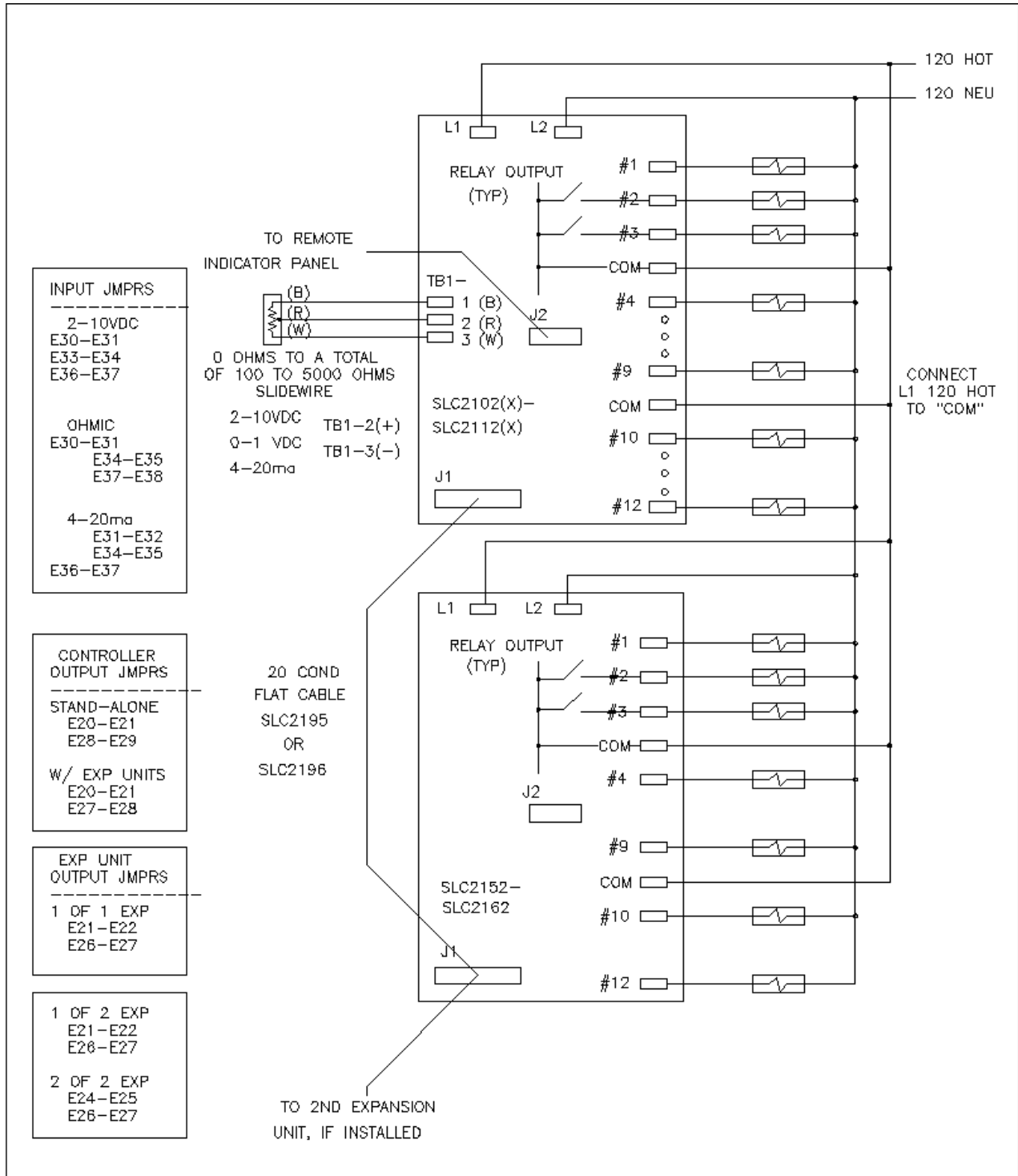

Figure 5 FIELD WIRING DIAGRAM

3. OPERATING INSTRUCTIONS

3.1 Startup and Adjustments

4.1.1 Verify that the wiring is in accordance with paragraph 2.0.

4.1.2 If an initial verification of the Controller Unit is desired, an ordinary 100-5K ohm, 1/2 Watt or larger potentiometer can be used as a Command Potentiometer to test the Control unit, and associated wiring.

Verify the controller is configured for *ohmic input*, for the test verification, per paragraph 2.1.

Disconnect the input signal and connect a potentiometer per the wiring diagram, Figure 5.

4.1.3 Turn the potentiometer fully counterclockwise (CCW).

Verify that the On Delay Timing Adjustment RV3, and Off Delay Timing Adjustment RV5, is set fully CCW or at the "MIN" setting.

4.1.4 Verify the wiring in the remainder of the Control System before energizing the line power.

4.1.5 Apply line power to the Control System.

4.1.6 Slowly turn the Command Potentiometer clockwise (CW).

Output stages should start to turn on.

Gradually increase the Command Potentiometer to full CW and verify that all output stages have been turned on.

Vary the Command Potentiometer between full CW and full CCW, and points in-between to verify proper sequencing operation.

The Controller will respond by turning on additional stages as the potentiometer is increased CW.

The Controller will turn off stages when the command potentiometer is turned CCW. The Controller, on decreasing demand, will turn off the one which has been turned on the longest. This type of sequencing will evenly distribute the wear on the contactors.

4.1.7 Turn the line power off.

4.1.8 Disconnect the Command Potentiometer (if used) and re-connect the input signal per wiring diagram of Figure 5.

4.1.9 Fuses

A single 2A fast-blow fuse is used on each Control or Expansion Unit. In the unlikely event one should fail, turn off the line power to the Control System and replace the failed fuse with an identical or equivalent type.

A Littelfuse 312002 or Bussman AGC 2A are suitable replacements.

4. TROUBLESHOOTING

	SYMPTOM	POSSIBLE CAUSE	REMEDY
4.1	Output stages do not turn on	Fuse blown	Replace F1
		COM terminals TT6 (6 and 12 step boards), TT13 (12 step boards)	Connect to L1 for contactors requiring 120V to energize
		On Time delay set too long	Turn RV3 CCW for less time delay
		Sensor not wired correctly	Wire sensor per Figure 5
4.2	Output stages do not turn off, or sequences erratically	E20-E27 jumpers incorrectly set	Set configuration jumpers per 2.2
		Off time delay set too long	Turn RV5 CCW for less time delay
4.3	All stages do not turn on at maximum command	Gain set too low	At maximum command, turn gain pot RV2 (ohmic, 1VDC, or 4-20 ma input) or pot RV4 (0-10V or 2- 10VDC) CW until all stages turn on.
4.4	All stages turn on before maximum command	Gain set too high	At maximum command, turn gain pot RV2 (ohmic, 1VDC, or 4-20 ma input) or pot RV4 (0-10V or 2- 10VDC) CCW until one stage turns off, then turn the pot CW until all stages turn on.
4.5	Stages do not turn off quickly enough	Off Delay RV5 incorrectly adjusted	Adjust RV5 for desired Off Delay

4.1 Troubleshooting Tips

- 5.1.1 Isolate the source of the problem to being either internal or external to the controller by disconnecting the external wiring, and driving the controller with a local input source.
- 5.1.2 **For slidewire or other ohmic inputs**, connect a Test potentiometer with a value of between 100 and 5000 ohms, 1/2 watt to TB1. TB1-1 is a 1 volt reference, TB1-2 is the wiper input, and TB1-3 is the circuit common.
- Rotate the potentiometer and monitor the quantity of relays and LEDs, which are activated. The quantity of LEDs should be proportional to the input signal. TB1-2 may be monitored for a voltage between 0 and 1 volt, which indicates the proportional amount of output stages to be activated.
- 5.1.3 **For voltage and current inputs**, connect a Test control source between TB1-2 (+) and TB1-3 (com). If your external circuit is driving the controller with a voltage or current source, and it is not convenient to drive it with a simulated control voltage or current, the controller may be TEMPORARILY configured for ohmic inputs. Perform step 5.1.2, then re-configure the controller for the correct input type.
- 5.1.4 If the trouble appears to be in the controller or any attached expansion units, isolate the problem to being a controller or expansion unit problem. **Turn off the power**, then disconnect the cascading cable to the expansion units, then TEMPORARILY reconfigure the main controller to operate in the stand-alone mode by changing the configuration jumpers to connect E28-E29, only. Test the unit as if it has only the quantity of stages on the main controller. If the unit operates normally, then the problem is in the expansion units. The main control may still be operated in the stand-alone mode to provide partial functionality to the system, until the expansion units may be repaired or replaced.
- 5.1.5 If the main control unit and the expansion units operate correctly in the local mode, re-connect the wiring, and drive the remote end of the wiring with an alternate control source, or substitute a potentiometer, after configuring the main board to accept ohmic inputs. This should determine whether the problem is with the remote controller, or with the external wiring.

5. SPECIFICATIONS

CONTROL AND EXPANSION UNITS

POWER:	120 VAC +/- 10% @ 15 VA max., single phase 60 Hz.
FUSE:	2A Fastblow, Littelfuse 312002 or equivalent. Bussman AGC 2A or equivalent
INPUT:	<p><u>CONTROL UNITS:</u></p> <ul style="list-style-type: none"> • Slidewire Sensor, 0 to 135 ohm (typ), or 0 to anything up to 5K ohm • Potentiometer, 0 to anything between 100 to 5K ohm total resistance • Voltage: 0-1 VDC, 2-10VDC • Current: 4-20 ma <p><u>EXPANSION UNITS:</u></p> <ul style="list-style-type: none"> • 20 Conductor Flat Cable from the Expandable Control Unit.
OUTPUT:	Relay Contact, Pilot Duty, 8A resistive @ 120 VAC, 5A 30 VDC <ul style="list-style-type: none"> • Limit continuous load to 135VA per relay • Standard units are equipped with varistors for use with 120 VAC control. • Units for 240 VAC control are available by special request.
FIELD WIRING:	1/4" quick-connect male terminals provided for all connections.
STEP TIME:	On Delay, Adjustable from approximately 1 sec to 1 minute. Off Delay, Adjustable from approximately ½ sec to 30 seconds.
SIZE:	2-6 stage Control and Expansion Units are: 5.75" by 6.75" by 2" max. 8-12 Control and Expansion Units are: 5.75" by 10.5" by 2" max.